

Model 120

Single Reduction Planetary Gear Reducer

Flange Mount

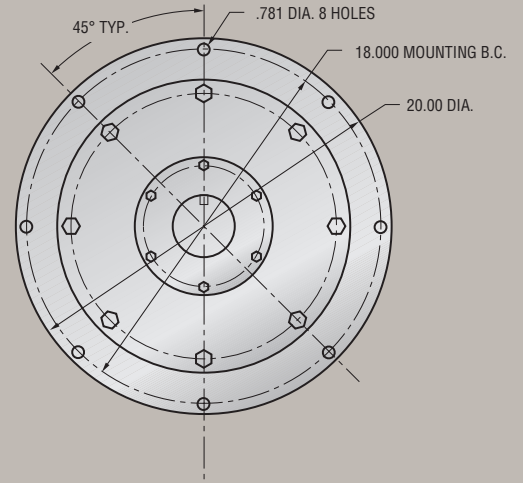
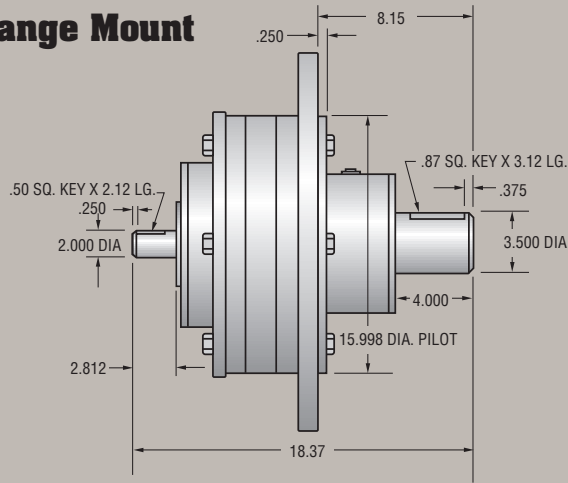

Foot Mount

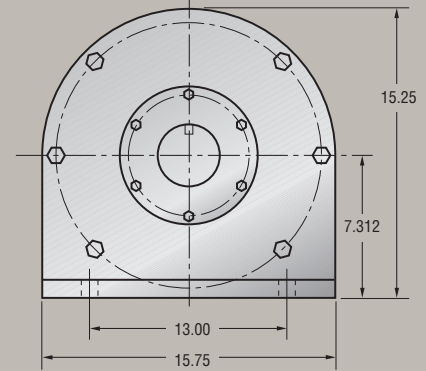
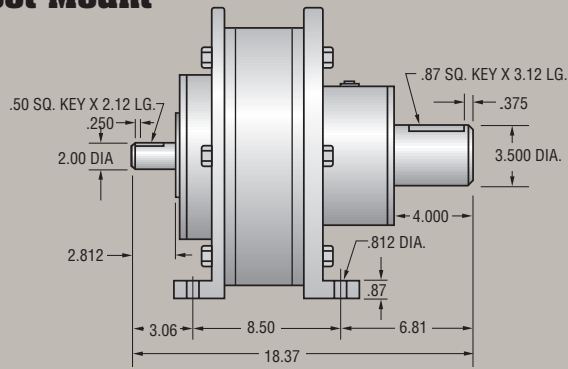

Flange or Foot Mount w/SAE or NEMA Input

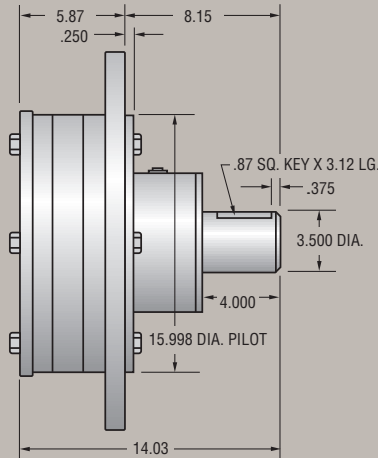

NEMA Electric Motor Direct Mount

"C" face direct couple of motor to speed reducer. No need for coupling or special motor mounts.

SAE Hydraulic Motor Direct Mount

2 bolt or 4 bolt direct couple of hydraulic motor to speed reducer. No need for coupling or special motor mounts.



Byrne
**Gear Corporation
of America**

- Planetary speed reducers
- High-speed increasers
- Custom design geared products

"The Problem Solver"

Model 120

Single Reduction Planetary Gear Reducer

Planetary Assembly	Ratios	OUTPUT HORSE POWER RATINGS (Adjusted for Thermal Efficiencies)						
		INPUT R.P.M.						
		100	580	720	870	1170	1430	1750
E	3.00	20.81	71.22	82.86	94.60	116.40	133.96	154.30
A	3.50	23.09	79.03	91.95	104.97	129.16	148.64	171.21
B	4.00	20.67	70.75	82.31	93.97	115.63	133.07	153.27
C	4.33	14.50	49.64	57.75	65.93	81.13	93.36	107.54
D	6.00	11.10	37.98	44.19	50.44	62.07	71.43	82.27

Ratings based upon uniform steady and moderate shock loading. See load factor chart for details.

OUTPUT SHAFT RADIAL (overhung) LOAD CAPACITIES (at output r.p.m.)								
R.P.M.	10	20	30	50	100	200	300	500
Radial Capacities (lbs.)	17,000	13,600	11,900	10,200	8,500	8,075	6,800	5,525

OUTPUT SHAFT THRUST LOAD CAPACITIES (at output r.p.m.)								
R.P.M.	10	20	30	50	100	200	300	500
Thrust Capacities (lbs.)	26,025	20,842	18,724	16,060	13,049	10,602	9,386	8,050

OUTPUT SHAFT MAXIMUM CONTINUOUS TORQUE CAPACITY: 50,390 lb./inches

OUTPUT SHAFT INTERMITTENT TORQUE CAPACITY: 100,480 lb./inches

WEIGHT: 300 lbs.

RATING SYSTEM: All Ratings Based Upon American Gear Manufacturers Association Standards

**If you use BYRNE GEAR products, you are in good company.
Join the thousands of satisfied customers
that choose the "Problem Solver".**

USX - Steel Division
General Motors
LTV Steel
Portland Cement
U.S. Air Force
Israeli Air Force
United Technologies
3M Company
U.S. Coast Guard
Tennessee Valley Authority
Union Carbide Corp.
Tritan Corporation
Armco Steel
Kuwati Oil Company
Exxon

NASA
E.I. Dupont
U.S. Navy
Fuller Company
Sikorsky
Bendix
Canadian Bearings Co.
Caterpillar Tractor Co.
Container Corp. Of America
Grotnes Metalforming
Ingersoll Rand Corp.
R.R. Donnelley & Sons
The Budd Company
Ohio State University
Mead Paper

Martin Marietta
Rockwell International
Bethlehem Steel
Ashland Petroleum
Republic Steel
Batelle Memorial Institute
Scott Paper
British Petroleum
FMC Corporation
Goodyear Tire & Rubber
Michael Byrne Mfg. Co.
MacGregor - Navire
Sandia Laboratories
National Ctr. for Atmospheric
Research



Byrne

GEAR CORPORATION OF AMERICA

301 Byrne Gear Drive
P. O. Box 1789
Mansfield, Ohio 44901
Telephone: (419) 522-GEAR(4327)
Fax: (419) 525-2386

E-mail: byrne@byrnegroup.com

Visit our web site at: www.byrnegroup.com

Part of The Byrne Group

Copyright © Byrne Gear Corporation of America
Printed in U.S.A. 697

"The Problem Solver"